



Crosswind Circuit

This briefing primarily deals with the differences between a normal circuit, where the wind is straight down the runway in use, or little wind exists, and a circuit where the wind is at an angle to the runway in use.

The student should already be familiar with compensating for drift on the crosswind and base legs of the circuit. However, when landing in a crosswind, the aeroplane must be aligned with the runway before touchdown. If this is not done, there is a risk of damage to the undercarriage and the aeroplane may run off the runway.

Objectives

To correctly position the aeroplane controls while taxiing.

To compensate for drift throughout the circuit.

To take off and land in crosswind conditions.

Considerations

During taxiing and throughout the takeoff and landing, when the wind is at an angle to the runway, the aeroplane will have a tendency to weathercock or swing nose into wind.

Since taxiing in any wind will invariably result in some crosswind being experienced, revise the correct positioning of the aeroplane's controls during taxiing.

Figure 1a

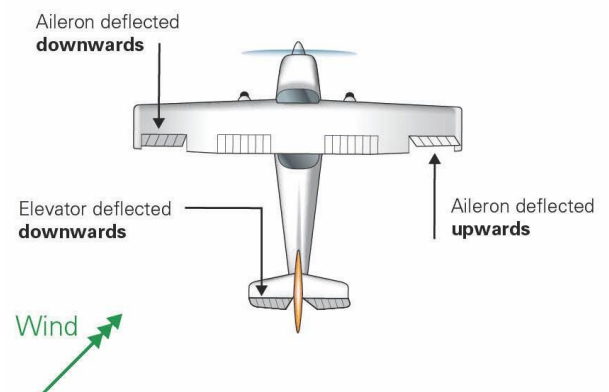
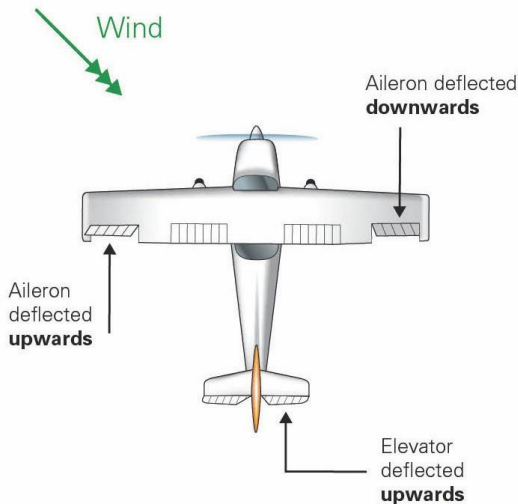

Figure 1b



When climbing out or approaching to land, with the wind at an angle to the runway, an allowance for drift will need to be made so that the aeroplane tracks straight over the ground along the extended centreline.

Maximum Demonstrated Crosswind The maximum demonstrated crosswind component (in knots) in the Flight Manual is the figure at which factory testing has shown that directional control can still be maintained. It is affected by the size of the rudder, its distance from the C of G, and the availability of asymmetric braking. It is not a legal limitation but a guide to what limit should be applied to crosswind landings. It is modified by several factors, for example, technique, individual currency and competency.

State the maximum demonstrated crosswind component for this aeroplane, as well as any club or organisation limit.

Calculation of Crosswind Component

To calculate the crosswind component the pilot must first know or estimate the wind velocity (W/V) – its speed and direction.

This information may be provided by METAR – routine meteorological reports, TAF – aerodrome forecasts, ATIS – the Automatic Terminal Information Service, the ATC control tower, or windsocks.

METAR and TAF winds are given in degrees **true** and must first be converted to magnetic in order to calculate the angular difference between runway heading (magnetic) and wind direction.

In some instances the crosswind component may be stated – requiring no further calculations.

Once the angular difference between wind direction and the runway heading is known, the various methods of calculating the crosswind component can be discussed.

Vector Diagram

The vector method requires pencil, paper, protractor and ruler. As an example, assume a W/V of 240 degrees magnetic at 20 knots and a runway heading of 210 degrees (RWY 21). Calculate the angular difference between the runway and the wind direction; this is the wind angle, in this case 30 degrees. Draw a vertical line to represent the runway. From near the bottom of this line, draw a line at the wind angle from the vertical, 20 units (wind speed) long. Break this vector down into its vertical and horizontal components and measure these to give headwind (15 knots) and crosswind (10 knots).

Figure 2

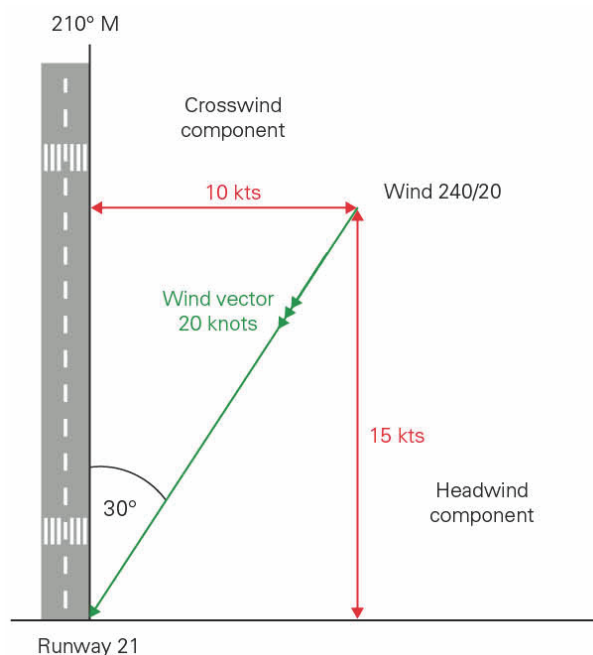

Flight Manual

Commonly, a vector diagram is supplied in the Flight Manual in graph form and is a more practical method of calculating crosswind.

It's a good idea to include a photocopy of this graph in the handout to this lesson and to have a large laminated version for reference during the briefing.

Navigation Computer

Although the presentation is a little different, the same calculation can be made using the navigation computer.

Windssocks

Most aviation windsocks are 25-knot windsocks. This means that when the wind strength is 25 knots the windsock stands straight out. The angular difference between runway and wind direction is estimated visually and may require a mental calculation to derive the crosswind component (see Formula below).

Tower

Where ATC is provided on the aerodrome you can request the crosswind component from the tower, but your student should be able to calculate it for themselves using one of the methods above.

Formula

The crosswind component is equal to the speed (V) of the wind multiplied by the sine of the angular difference ($XWC = V \times \text{Sine } \theta$). Therefore, in the example given above (Rwy 21 – W/V 240/20) the angular difference is 30 degrees, and the sine of 30 degrees is 0.5. This means that half the wind strength is crosswind ($20 \times 0.5 = 10$).

To be completely accurate this method requires a calculator or memorisation of the various sines of angles between 0 and 90 degrees. However, there is a simple way to estimate it.

Imagine that the minutes on the face of your watch are equivalent to the angular difference between the runway and the wind direction. If the difference is 30 degrees, then thirty minutes is half way around your watch face, therefore the

crosswind component is half the wind strength. If the angular difference is 45 degrees, then that is three-quarters of the way round your watch face and the crosswind component is three-quarters of the wind strength. If the angular difference is 60 degrees or more then consider the crosswind component to be the full strength of the wind.

Figure 3



Further Considerations

The ability to maintain directional control about the normal axis is the limiting factor for crosswind landings. Although it may be easy enough to keep the aeroplane aligned with the runway during the round-out and landing, as the airspeed decreases, rudder effectiveness will reduce and it may be difficult to prevent weathercocking. Therefore, as the crosswind component increases, the amount of flap used for the landing is normally reduced. This reduces the surface area on which the crosswind can act after landing and therefore improves directional control.

Although the landing distance may be adequate when calculated using the group rating system or P-charts, any landing with reduced flap will increase the landing roll. In addition, if the crosswind is not steady, an increase in approach speed may be required to compensate for windshear and gusts.

Therefore, the pilot-in-command must consider the runway's overall suitability in relation to crosswind component, approach/threshold speed and available length.

Remind the student to anticipate the effect of a strong crosswind on the groundspeed, in particular on base leg.

Airmanship

Calculating the crosswind component, assessing the gustiness of the day, reviewing the aeroplane's limitations and discussing the configuration to be used all contribute to improving the student's situational awareness.

The aeroplane can land in crosswinds of greater than the demonstrated crosswind component provided the correct technique is used, and it is entirely **necessary** to do so.

Where this exercise is simulated using a non-active runway, remember aircraft taking off and landing into wind have right of way.

Aeroplane Management

The controls must be positioned correctly, taking account of the wind, when taxiing, on takeoff and landing.

Discuss the use of brakes as required to assist directional control.

Human Factors

In accordance with aeronautical decision making (ADM) principles, the student should be asked on subsequent flights to assess other runways for landing suitability.

Air Exercise

Takeoff

On lining up, the high reference point used to keep straight during the climb will need to be adjusted from normal to prevent drift, and provide a straight track over the ground along the extended centreline. The ailerons are fully deflected into wind and the elevator maintained neutral or very slightly down.

During the takeoff roll the amount of aileron is reduced as the increasing speed makes the ailerons more effective and some weight retained on the nosewheel to improve directional control.

At a safe flying speed the aeroplane is rotated with ailerons neutral. The aim is to lift off cleanly, preventing the aeroplane from skidding sideways

across the runway. In addition, the higher rotate speed will allow the aeroplane to accelerate quickly to the nominated climb speed. Using the nominated high reference point as a guide, after liftoff a gentle balanced turn into wind is made to track along the climb-out path.

Circuit

During the climb out, ensure the wings are level and the aeroplane is in balance. Check for straight tracking and adjust the reference point as necessary to maintain the extended centreline.

On the crosswind leg, select a reference point with an allowance for drift in the normal way. A component of head or tailwind may become apparent in the distance travelled over the ground to reach circuit altitude.

The turn onto downwind should be made at the same distance out as a normal circuit. A wider downwind leg may be advisable if a particularly strong crosswind toward the runway exists, as this will decrease the time spent on the base leg. More commonly the effects of a headwind or tailwind on the crosswind leg will require less or more anticipation of when to start the turn onto downwind. A suitable reference point, so as to track parallel to the runway, is chosen. The approach is assessed and a decision made on runway suitability, approach/threshold speed and maximum flap setting to be used. The correctness of the downwind spacing is assessed and if necessary, the reference point altered to maintain a parallel track.

The turn onto base is normal and continued onto a suitable reference point with an allowance for drift.

Once established on base leg, additional flap up to the maximum to be used for the landing is normally extended.

The head or tailwind component experienced on base will affect the turn onto final and must be anticipated. The turn is continued onto a suitable reference point into wind that allows for drift, and tracks the aeroplane straight along the extended centreline.

Throughout the descent the aiming point is monitored in the normal way and the power adjusted to maintain a steady rate of descent to touchdown – power controls the rate of descent.

The recommended crosswind landing technique is a combination of the following two methods, the ‘kick-straight’ method and the ‘wing-down’ method.

The Kick-Straight Method

The advantage of this method is that the aeroplane is flown in balance throughout the approach, round-out and hold-off. The disadvantage is that it is not easy to master.

On the approach the aeroplane is crabbed into wind, and just before touchdown, brisk or positive rudder is used to yaw the aeroplane’s nose into line with the runway. Into-wind aileron is used to keep the wings level.

Although this method sounds simple at first, it takes considerable skill in timing the application of rudder. Too early, and the aeroplane will drift downwind, touching down with sideways loads, perhaps off the runway. Too late, and the aeroplane will touch down at an angle to the runway, applying large sideways loads and the aeroplane may rapidly depart the runway.

The Wing-Down Method

The advantage of this method is its ease of execution, but there may be limitations in the Flight Manual that affect this method.

On short final the aeroplane’s nose is aligned with the runway by applying rudder and sufficient into wind aileron, to prevent drift, while controlling speed until the flare with elevator. This results in the aeroplane sideslipping into wind at a rate that negates the drift.

The round-out and hold-off are flown in this wing-down attitude and the landing made on the windward wheel first.

Although this method sounds more difficult, it is easier to execute and requires less judgement.

Many modern light aeroplanes have a restriction on sideslipping, especially with flap extended, and therefore the recommended procedure is a combination of these two methods.

The Combination Method

Throughout the approach, the aeroplane is crabbed into wind, in balanced flight, preventing drift.

During the round-out, the wing down method is applied. The aeroplane’s nose is aligned with the runway through smooth rudder application and sufficient aileron into wind used to prevent drifting off the centreline.

Unless a strong crosswind exists this should not require full or even large control deflections. If large amounts of aileron are required to maintain the centreline, then it is unlikely that rudder effectiveness will be sufficient to keep straight throughout the landing roll. In this situation, unless rudder effectiveness can be improved with an increase in speed, a go around should be carried out and an approach with a different speed/flap configuration conducted. Alternatively the runway’s suitability may need to be reconsidered.

The landing is made on the windward wheel, which will create a couple that lowers the other main wheel. The rudder is centralised and the nosewheel lowered rather than held off, and some weight maintained on the nosewheel for directional control. At the same time, aileron into wind is increased as the speed reduces.

Throughout the landing a small amount of power (1200 rpm) may be used to improve control and the throttle closed at touchdown.

Keep straight on the runway centreline by reference to a point at the far end of the runway and apply differential braking as required.

No more than neutral elevator should be used to put some weight on the nosewheel so as to avoid wheel-barrowing.

Airborne Sequence

On the Ground

Ensure that the student places the controls in the right position, allowing for wind.

6 Circuit training: Crosswind Circuit

The Exercise

By now, the student should be well practised in the circuit procedures. However, for the crosswind landings you will need to demonstrate, follow through, talk through and then allow the student to practise with decreasing input from you.

Where practical, the student should be gradually introduced to crosswinds of increasing intensity, commensurate with skill, including experiencing the various speed/flap configurations appropriate for varying wind conditions.

Do not combine a flapless and crosswind landing at these early stages, but it is still possible for the student to practise the emergency procedures previously covered.